



MX-X

MX-Q

## Technical specifications MX-X, MX-Q

Order picking stackers with turret head/telescopic fork



first in intralogistics

MX-X order picker with turret head.

				STILL	STILL		
Features	1.1	Manufacturer					
	1.2	Type designation of manufacturer		MX-X telescopic mast	MX-X triplex mast with free lift		
	1.3	Drive (electric, diesel, petrol, LPG, Mains)		Electric	Electric		
	1.4	Operation (tiller, pedestrian, stand-on, rider seated, order picker)		Stand-on/rider seated	Stand-on/rider seated		
	1.5	Rated capacity/load	Q	kg	500 - 1500	500 - 1500	
	1.6	Load centre	c	mm	600	600	
1.9	Wheel base	y	mm	1586 - 2184	1586 - 2184		
Weights	2.1	Tare weight		kg	variable*		
	2.2	Axle load laden	Drive end/load end	kg	variable*		
	2.3	Axle load unladen	Drive end/load end	kg	variable*		
Wheels   drive gear	3.1	Tyres (Solid rubber, pneumatic, Polyurethane)			Polyurethane		
	3.2	Tyre diameter/width	drive end	mm	400/140	406/170	
	3.3	Tyre diameter/width	load end	mm	370/160	370/160	
	3.5	No. of wheels (x=driven)	Drive end/load end		1x/2	1x/2	
	3.6	Track width	load end	b <sub>10</sub>	mm	variable*	
	3.7	Track width	drive end	b <sub>11</sub>	mm	0	
	Dimensions	4.2	Closed mast height	h <sub>1</sub>	mm	2400 - 7400	2900 - 5900
4.3		Free lift	h <sub>2</sub>	mm	-	1650 - 4650	
4.4		Lift	h <sub>3</sub>	mm	2200 - 11800	5050 - 12850	
4.5		Extended mast height	h <sub>4</sub>	mm	4755 - 14355	7605 - 15405	
4.7		Height of overhead guard (cabin)	h <sub>5</sub>	mm	2555	2555	
4.8		Height of seat/stand	h <sub>7</sub>	mm	430	430	
4.11		Auxiliary fork lift	h <sub>9</sub>	mm	1675 - 2375	1675 - 2375	
4.14		Stand height, raised	h <sub>12</sub>	mm	2645 - 12245	5495 - 13295	
4.14.1		Reach height (h <sub>12</sub> + 1600 mm)	h <sub>28</sub>	mm	4245 - 13845	7095 - 14895	
4.15		Height lowered	h <sub>13</sub>	mm	80	80	
4.19		Overall length (incl. fork)	l <sub>1</sub>	mm	variable*	variable*	
4.21		Overall width	Chassis/load wheel axle	b <sub>1</sub> /b <sub>2</sub>	mm	1160/1160 - 1800	1160/1160 - 1800
4.22		Fork dimensions		s/e/l	mm	variable*	variable*
4.24		Width of fork carriage		b <sub>3</sub>	mm	variable*	variable*
4.25		Outer fork width		b <sub>5</sub>	mm	variable*	variable*
4.27		Width over guide rollers		b <sub>6</sub>	mm	1170 - 1919	1170 - 1919
4.29		Shift, sideways		b <sub>7</sub>	mm	variable*	variable*
4.31		Floor clearance laden, beneath mast		m <sub>1</sub>	mm	40	40
4.32		Floor clearance laden, centre wheel base		m <sub>2</sub>	mm	87	87
4.34		Width of working aisle		A <sub>st</sub>	mm	variable*	variable*
4.35		Turning radius		W <sub>a</sub>	mm	variable*	variable*
4.38	Distance to pivot point fork		l <sub>8</sub>	mm	variable*	variable*	
4.39	Length of shift carriage		A	mm	variable*	variable*	
4.40	Width shift frame		B	mm	variable*	variable*	
4.41	Width shift carriage		F	mm	variable*	variable*	
4.42	Width of transition aisle	min.	A <sub>u</sub>	mm	variable*	variable*	
Performance data	5.1	Driving speed	laden/unladen	km/h	variable*		
	5.2	Lift speed	laden/unladen	m/s	variable*		
	5.3	Lowering speed	laden/unladen	m/s	variable*		
	5.4	Shift speed	laden/unladen	m/s	variable*		
	5.9	Acceleration time (10 m)	laden/unladen	s	variable*		
	5.10	Operation brake			generator	generator	
Electric motor	6.1	Drive motor, capacity S2 = 60 min		kW	7		
	6.2	Lift motor, capacity at S3 = 15%		kW	20 - 24		
	6.3	Battery according to IEC 254-2; A, B, C, no			IEC 254-2; A	IEC 254-2; A	
	6.4	Battery type, voltage, rated capacity K <sub>s</sub>		V/Ah	PzS, 48 V**, 480 - 1240 Ah/ PzS, 80 V, 420 - 930 Ah	PzS, 48 V**, 480 - 1240 Ah/ PzS, 80 V, 420 - 930 Ah	
	6.5	Weight of battery ± 5% (depending on manufacturer)		kg	1238 - 2310	1238 - 2310	
Other	8.1	Type of truck control			micro processor		
	8.4	Sound level, driver's ear		dB (A)	68		

\* Scalable values depend on the individual customer requirements.

\*\* 48-V performance class not available for all configurations.

### Telescopic mast.

(All heights indicated in mm.)

Closed height $h_1$	Overall lift above floor $h_{25}$ ( $h_3 + h_9 + h_{13}$ )	Overall lift $h_{24}$ ( $h_3 + h_9$ )	Main lift $h_3$	Height lowered $h_{13}$	Auxiliary lift $h_9$	Stand height $h_{12}$ ( $h_3 + h_7$ )	Reach height $h_{28}$ ( $h_7 + 1600$ )	Max. height $h_4$ ( $h_3 + h_5$ )
7400	13535	13475	11800	60	1675	12245	13845	14355
6900	12535	12475	10800	60	1675	11245	12845	13355
6400	11735	11675	10000	60	1675	10445	12045	12555
5900	10735	10675	9000	60	1675	9445	11045	11555
5400	9935	9875	8200	60	1675	8645	10245	10755
4900	8935	8875	7200	60	1675	7645	9245	9755
4400	7935	7875	6200	60	1675	6645	8245	8755
3900	6935	6875	5200	60	1675	5645	7245	7755
3400	5935	5875	4200	60	1675	4645	6245	6755
2900	4935	4875	3200	60	1675	3645	5245	5755
2400	3935	3875	2200	60	1675	2645	4245	4755

(Telescopic mast optimised for 1000 kg to  $h_1 = 4900$  mm and optimised for 1150 kg to  $h_1 = 5900$  mm.)

### Triplex mast with free lift.

(All heights indicated in mm.)

Closed height $h_1$	Overall lift above floor $h_{25}$ ( $h_3 + h_9 + h_{13}$ )	Overall lift $h_{24}$ ( $h_3 + h_9$ )	Main lift $h_3$	Free lift $h_2$ ( $h_1 - 1250$ )	Height lowered $h_{13}$	Auxiliary lift $h_9$	Stand height $h_{12}$ ( $h_3 + h_7$ )	Reach height $h_{28}$ ( $h_7 + 1600$ )	Max. height $h_4$ ( $h_3 + h_5$ )
5900	14585	14525	12850	4650	60	1675	13295	14895	15405
5400	13285	13225	11550	4150	60	1675	11995	13595	14105
4900	11785	11725	10050	3650	60	1675	10495	12095	12605
4400	10485	10425	8750	3150	60	1675	9195	10795	11305
3900	9185	9125	7450	2650	60	1675	7895	9495	10005
3400	8085	8025	6350	2150	60	1675	6795	8395	8905
2900	6785	6725	5050	1650	60	1675	5495	7095	7605

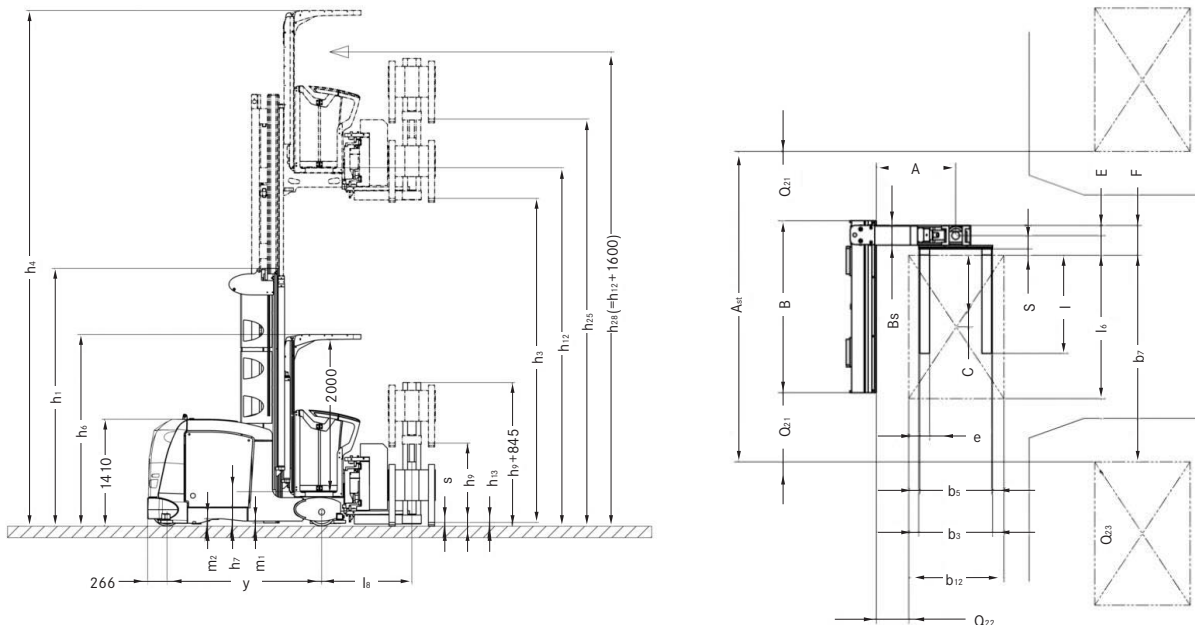
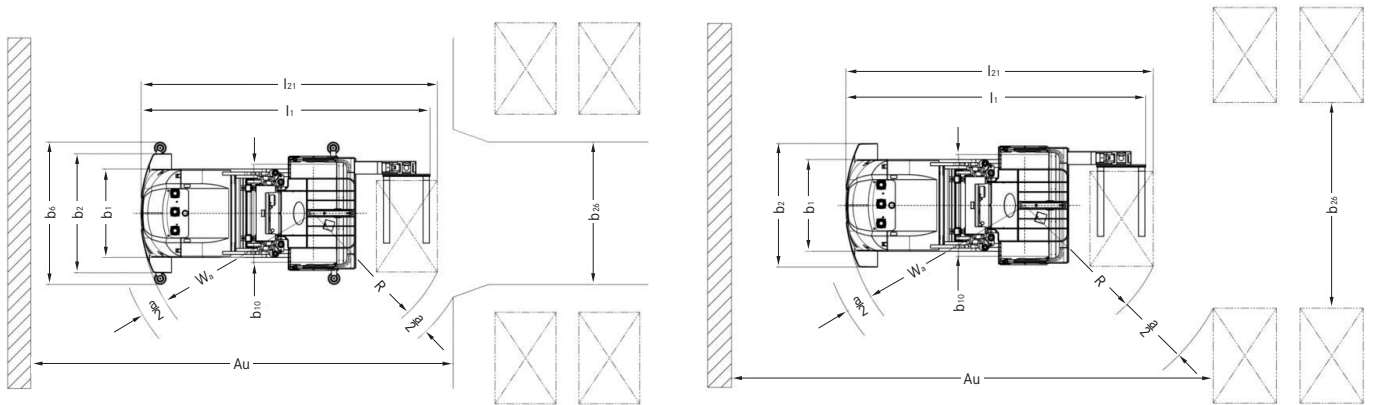

## MX-Q order picker with telescopic fork.

				STILL	STILL		
Designation	1.1	Manufacturer					
	1.2	Type designation of manufacturer		MX-Q Telescopic mast	MX-Q Triplex mast with free lift		
	1.3	Drive (Electric, diesel, petrol, LPG, mains)		Electric	Electric		
	1.4	Operation (tiller, pedestrian, stand-on, rider seated, order picker)		Stand-on/rider seated	Stand-on/rider seated		
	1.5	Rated capacity/load	Q	kg	500 - 1250	500 - 1250	
	1.6	Load centre	c	mm	600	600	
Weights	1.9	Wheel base	y	mm	1586 - 2184	1586 - 2184	
	2.1	Tare weight		kg	variable*	variable*	
	2.2	Axle load laden	drive end/load end	kg	variable*	variable*	
Wheels   drive gear	2.3	Axle load unladen	drive end/load end	kg	variable*	variable*	
	3.1	Tyres (solid rubber, pneumatic, Polyurethane)			Polyurethane	Polyurethane	
	3.2	Tyre diameter/width	drive end	mm	400/140	406/170	
	3.3	Tyre diameter/width	load end	mm	370/160	370/160	
	3.5	No. of wheels (x=driven)	drive end/load end		1x/2	1x/2	
	3.6	Track width	load end	b <sub>10</sub>	mm	variable*	variable*
	3.7	Track width	drive end	b <sub>11</sub>	mm	-	-
Dimensions	4.2	Closed mast height	h <sub>1</sub>	mm	2400 - 7400	2900 - 5900	
	4.3	Free lift	h <sub>2</sub>	mm	-	1650 - 4650	
	4.4	Lift	h <sub>3</sub>	mm	2200 - 11800	5050 - 12850	
	4.5	Extended mast height	h <sub>4</sub>	mm	4755 - 14355	7605 - 15405	
	4.7	Height of overhead guard (cabin)	h <sub>5</sub>	mm	2555	2555	
	4.8	Height of seat/stand	h <sub>7</sub>	mm	430	430	
	4.11	Auxiliary fork lift	h <sub>9</sub>	mm	800 - 1500	800 - 1500	
	4.14	Stand height, raised	h <sub>12</sub>	mm	2645 - 12245	5495 - 13295	
	4.14.1	Reach height (h <sub>12</sub> + 1600 mm)	h <sub>28</sub>	mm	4245 - 13845	7095 - 14895	
	4.15	Height lowered	h <sub>13</sub>	mm	380	380	
	4.19	Overall length (incl. fork)	l <sub>1</sub>	mm	variable*	variable*	
	4.21	Overall width	Chassis/load wheel axle	b <sub>1</sub> /b <sub>2</sub>	mm	1160/1160 - 1800	1160/1160 - 1800
	4.22	Fork dimensions		s/e/l	mm	variable*	variable*
	4.24	Width of fork carriage		b <sub>3</sub>	mm	-	-
	4.25	Outer fork width		b <sub>5</sub>	mm	variable*	variable*
	4.27	Width over guide rollers		b <sub>6</sub>	mm	1170 - 1919	1170 - 1919
	4.29	Shift, sideways		b <sub>7</sub>	mm	variable*	variable*
	4.31	Floor clearance laden, beneath mast		m <sub>1</sub>	mm	40	40
	4.32	Floor clearance laden, centre wheel base		m <sub>2</sub>	mm	87	87
	4.34	Width of working aisle		A <sub>st</sub>	mm	variable*	variable*
4.35	Turning radius		W <sub>a</sub>	mm	variable*	variable*	
4.38	Distance to fork pivoting point		l <sub>8</sub>	mm	variable*	variable*	
4.39	Length of shift carriage		A	mm	-	-	
4.42	Width of transition aisle	min.	A <sub>w</sub>	mm	variable*	variable*	
Performance data	5.1	Driving speed	laden/unladen	km/h	variable*	variable*	
	5.2	Lift speed	laden/unladen	m/s	variable*	variable*	
	5.3	Lowering speed	laden/unladen	m/s	variable*	variable*	
	5.4	Shift speed	laden/unladen	m/s	variable*	variable*	
	5.9	Acceleration time (10 m)	laden/unladen		s	variable*	variable*
	5.10	Operation brake				generator	generator
Electric motor	6.1	Drive motor, capacity S2 = 60 min		kW	7	7	
	6.2	Lift motor, capacity at S3 = 15%		kW	20 - 24	20 - 24	
	6.3	Battery according to IEC 254-2; A, B, C, no			IEC 254-2; A	IEC 254-2; A	
	6.4	Battery type, voltage, rated capacity K <sub>s</sub>		V/Ah	PzS, 48 V**, 480 - 1240 Ah/ PzS, 80 V, 420 - 930 Ah	PzS, 48 V**, 480 - 1240 Ah/ PzS, 80 V, 420 - 930 Ah	
	6.5	Weight of battery ± 5% (depending on manufacturer)		kg	1238 - 2310	1238 - 2310	
Other	8.1	Type of truck control			micro processor	micro processor	
	8.4	Sound level, driver's ear		dB (A)	68	68	

\* Scalable values depend on the individual customer requirements.

\*\* 48-V performance class not available for all configurations.

### Telescopic mast.

(All heights indicated in mm.)

Closed height $h_1$	Overall lift above floor $h_{25}$ ( $h_3 + h_9 + h_{13}$ )	Overall lift $h_{24}$ ( $h_3 + h_9$ )	Main lift $h_3$	Height lowered $h_{13}$	Auxiliary lift $h_9$	Stand height $h_{12}$ ( $h_3 + h_7$ )	Reach height $h_{28}$ ( $h_7 + 1600$ )	Max. height $h_4$ ( $h_3 + h_5$ )
7400	12980	12600	11800	380	800	12245	13845	14355
6900	11980	11600	10800	380	800	11245	12845	13355
6400	11180	10800	10000	380	800	10445	12045	12555
5900	10180	9800	9000	380	800	9445	11045	11555
5400	9380	9000	8200	380	800	8645	10245	10755
4900	8380	8000	7200	380	800	7645	9245	9755
4400	7380	7000	6200	380	800	6645	8245	8755
3900	6380	6000	5200	380	800	5645	7245	7755
3400	5380	5000	4200	380	800	4645	6245	6755
2900	4380	4000	3200	380	800	3645	5245	5755
2400	3380	3000	2200	380	800	2645	4245	4755

(Telescopic mast optimised for 1000 kg to  $h_1 = 4900$  mm and optimised for 1150 kg to  $h_1 = 5900$  mm.)

### Triplex mast with free lift.

(All heights indicated in mm.)

Closed height $h_1$	Overall lift above floor $h_{25}$ ( $h_3 + h_9 + h_{13}$ )	Overall lift $h_{24}$ ( $h_3 + h_9$ )	Main lift $h_3$	Free lift $h_2$ ( $h_1 - 1250$ )	Height lowered $h_{13}$	Auxiliary lift $h_9$	Stand height $h_{12}$ ( $h_3 + h_7$ )	Reach height $h_{28}$ ( $h_7 + 1600$ )	Max. height $h_4$ ( $h_3 + h_5$ )
5900	14030	13650	12850	4650	380	800	13295	14895	15405
5400	12730	12350	11550	4150	380	800	11995	13595	14105
4900	11230	10850	10050	3650	380	800	10495	12095	12605
4400	9930	9550	8750	3150	380	800	9195	10795	11305
3900	8630	8250	7450	2650	380	800	7895	9495	10005
3400	7530	7150	6350	2150	380	800	6795	8395	8905
2900	6230	5850	5050	1650	380	800	5495	7095	7605

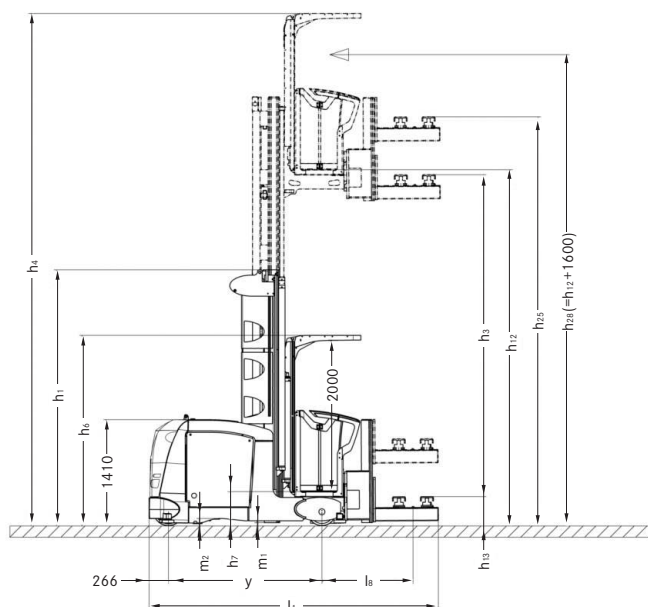
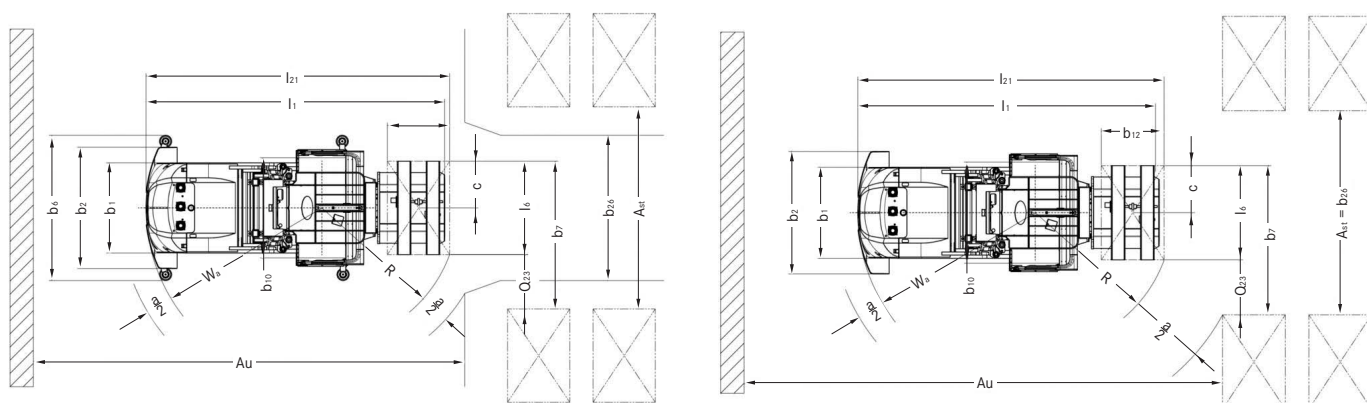

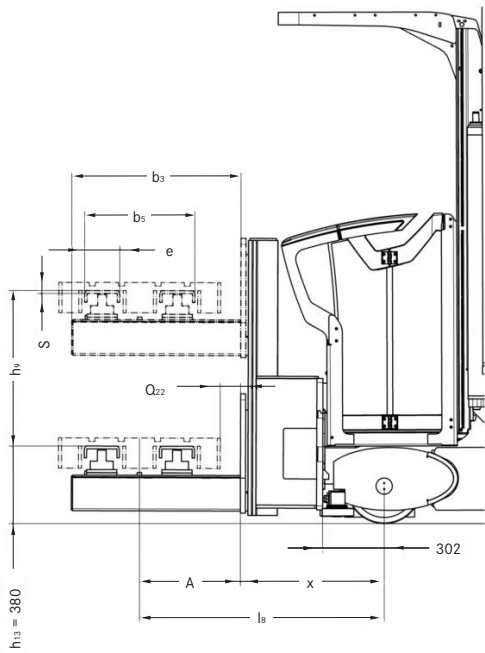

**Standard telescopic fork version.**

- Narrow aisles.
- Minimum space requirements for the transition aisle.

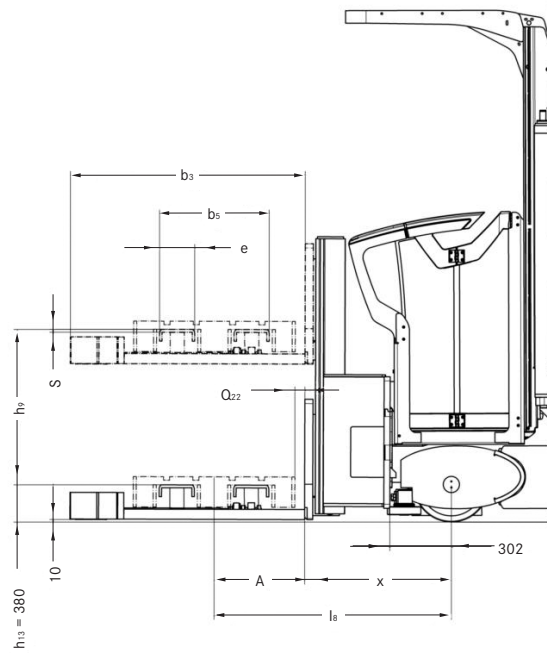

**Low telescopic for versions.**

- The lowest rack level can be as low as 100 mm above floor for optimum utilisation of space in the lower rack levels.
- Narrow working aisles, minimum space requirements in the transition aisle.

Standard telescopic fork h <sub>13</sub> = 380 mm									a <sub>21</sub> = 90 mm	a = 200 mm	Load capacity
Model	l <sub>6</sub> x b <sub>12</sub> Pallet	A	a <sub>22</sub>	x	l <sub>8</sub>	h <sub>9</sub>	b <sub>3</sub>	b <sub>7</sub>	A <sub>st</sub> min.	Au min./nom.	Q max.
MX-Q	1200 x 800	500	100	710	1210	variable*	1055	1290	1380	variable*	1250
	1200 x 1000	600	100	710	1310	variable*	1055	1290	1380	variable*	1250
	1200 x 1200	700	100	710	1410	variable*	1305	1290	1380	variable*	1000
	1240 x 835	500	82	710	1210	variable*	1055	1330	1420	variable*	1250
	1300 x 1300	700	50	710	1410	variable*	1355	1390	1480	variable*	1000

Flat telescopic fork h <sub>13</sub> = 180 mm									a <sub>21</sub> = 90 mm	a = 200 mm	Load capacity
Model	l <sub>6</sub> x b <sub>12</sub> Pallet	A	a <sub>22</sub>	x	l <sub>8</sub>	h <sub>9</sub>	b <sub>3</sub>	b <sub>7</sub>	A <sub>st</sub> min.	Au min./nom.	Q max.
MX-Q	1200 x 800	450	50	725	1175	variable*	1165	1290	1380	variable*	1250
	1200 x 1000	550	50	725	1275	variable*	1365	1290	1380	variable*	1000
	1200 x 1200	650	50	725	1375	variable*	1565	1290	1380	variable*	800
	1240 x 835	450	30	725	1175	variable*	1165	1330	1420	variable*	1250
	1300 x 1300	700	50	725	1425	variable*	1665	1390	1480	variable*	800

\* Scalable values depend on the individual customer requirements.

**Made for any warehouse.**

The modularity of the MX-X with a turret head or of the MX-Q with a telescopic fork adapts these trucks perfectly to any warehouse. The scalable dimensions and performance will always match any application and guarantee you best possible price-performance ratio.

Together with AC technology Optispeed stands for high dynamics and higher turnaround speeds consuming less energy at lower operation costs. Together with the energy recuperation when braking or lowering the main lift this allows longer operation times per battery charging cycle.

**OPTISPEED.**

The high performance and the optimum technical conditions of the MX-X are only made full use of when driving, lifting and controlling all the auxiliary movements by OPTISPEED. The precise height measuring system, also accounting for the auxiliary lift allows to optimise driving profiles and load change cycles by adjusting the acceleration and deceleration values. In combination with the dynamic and intelligent load weight diagram, OPTISPEED supports

the driver in the warehouse. In addition the performance can be increased by the optional load sensing and load weight sensing features for even higher turnaround, comfort and safety. OPTISPEED 4.0 allows semi-automatic approach to storage bays. The position of the bay being indicated by the warehouse management system, for example, and the truck will navigate to the right position in the aisle. This leads to higher safety and increased productivity.

**OPTISAFE.**

OPTISAFE allows easily assigning truck actions, safety functions and speeding settings to defined zones inside the aisles. Up to 255 aisles can be covered by adding OPTISAFE functions at any time. Each individual aisle is recognised when the vehicle enters the aisle and the functions can be assigned accordingly. The absolute, redundant distance measuring by RFID transponders in the floor or by barcodes on the rack posts forms the basis for a safe system. OPTISAFE stands for higher safety and flexibility inside the aisle.



## Ergonomics.

The STILL driver's compartment has been designed in accordance with the latest findings in ergonomics and offers an optimum workspace for all the different applications. The large cabin is mounted on low-vibration supports to suppress the oscillations from the load. It has a very low access and soft upholstery at knee-height the driver can lean against when order picking. The vertical and horizontal adjustment of the driver's seat and the tilt-adjustment of the seat cushion allow great comfort, also if the drivers change frequently. The tilting barrier reduces the distance between the truck and the rack facilitating access to the rack for order picking. A multi-function accessory bar on the railing allows mounting the modular accessory and storage compartments, permitting the individual components to be placed anywhere on the bar.

## Cabins.

- Combi: for order picking and/or stacker operation
- Stacker: with raised seat position for pure stacker operation
- Comfort: for more freedom of movement.
- Cold store cabin: fully insulated for cold stores up to -30 °C.

## Control panel.

The right control panel for every application:

- Multi-functional control panel: centrally mounted on the railing. Adjustable in height, distance from the driver and tilt. This allows best operability and function making the large display easy to read.
- The control elements are integrated into the armrests of the driver's seat. In addition the height of the armrests can be adjusted individually to allow standing and seated operation. Also they can be folded up with power support to facilitate access to the side. The display is easy to read and is mounted on the railing.

## Safety.

- High safety by contactless two-hand control for all drive and lift movements.
- Smaller aisle widths by larger safety distances due to the turret head with integrated side shift.
- Electric battery lock monitor.
- All the trucks meet the requirements of the machine guide line 98/37/EG and are marked with the CE label.
- STILL is certified in accordance with ISO 9001 by the Germanic Lloyd.

## Dependability.

- Tested and proven common parts from the STILL range.
- Torsion free steel construction of the chassis and the mast for low oscillations when moving heavy loads.
- Sophisticated heat balance in the drive compartment with active, temperature controlled cooling for a long service life of the components.
- Long service life of the battery by battery management for optimum power consumption and avoidance of peak currents.
- Maintenance free 48 V and 80 V AC drives with low wear, combined with power free MOSFET technology. Little wiring by proven CAN bus system for additional dependability.

## Service and maintenance.

- 1000-hour service interval.
- Quick diagnostics via notebook and easy access to all components that need maintenance combined with high availability of all needed parts guarantying short service times and outstanding availability.
- On line diagnosis and service support are available with the Online-X module.

## Additional equipment.

- Rail or wire guidance inside the aisle.
- Telescopic mast or triplex mast with free lift.
- Turret head/telescopic fork with auxiliary lift.
- Mechanically increased residual capacity.
- Overshift function for the turret head.
- Various fork carriages and fork versions.
- Hydraulic fork positioner with three basic versions.
- Toothed gear guard for the turret head (recommended when handling bagged goods).
- Different battery capacities of 48 V and 80 V.
- Battery roller frame to change the battery over the side.
- Side battery compartment covers.
- Driver's cabin: Combi, stacker, comfort and cold store up to -30 °C.
- Control panel integrated into the arm rests.
- Wind screen on load end, glass pane integrated into the railing.
- Glazed swivel doors as wind screens on the sides.
- Tilting barrier with active lock.
- Passenger operation for one more person.
- Heated or air-suspended comfort cabin.
- Camera system with 180 ° field of vision to drive end.
- Macrolon overhead guard cover.
- Load wheel brake for increased capacity
- Anti-static and cold store version.
- Mounting system for options and additional attachments.
- Writing pad and storage compartment with bottle holder.

## Additional electric equipment.

- Enhanced performance for driving and lifting.
- Automatic stop systems: RFID, magnets, floor sheets and reflectors.
- Switch-off of driving, lifting and fork movements.
- LED work place lighting.
- Mirror module with integrated LED spot lights and silent two level fan.
- OPTISPEED 3.x with load sensing, load weight sensing or load weight measuring.
- OPTISAFE for higher functionality and higher safety inside the aisle.
- Contactless collision guard on overhead guard.
- Intercom system for cold store cabin.
- Automatic fork cycle.
- Lift height pre-selection.
- Standardised interface for STILL MMS data terminal with scanner and printer.
- Integrated personnel safety system.
- Online-X module for remote diagnostics and service support.
- Mobile personal safety system.
- Access permission by PIN code or FleetManager.
- Semi-automatic bay approach with OPTISPEED 4.0.
- Automating interface for fully automatic operation.

